

NITOHULLMAC XG Series Key to Application

Nitto



Cautions for use

- Please apply under good weather.
- If rain, cloud of dust, freezing, or dew condensation is expected, please avoid application.
- If the above is expected to occur when beginning or ending the application, please prepare an appropriate covering.
- When applying indoors, make sure to ventilate the room well.

Nitto Denko Corporation

Tokyo Sales Branch: 10th Fl., East Tower, Gate City Ohsaki, 1-11-2, Ohsaki, Shinagawa-ku, Tokyo 141-0032, Japan

TEL: +81-3-5740-2035 FAX: +81-3-5740-2251 <http://www.nitto.com/jp/en/>

CATALOG CODE: 11206 Issued in October 2013

1103F00 @
1310R00

Straight pipes

Application procedure

| Straight pipes | Elbows | Tees | Flanges | Valves |
|--------------------------|---|---------------------------------------|-----------------|---|
| Around the base of tanks | Around the base of tanks reinforcing member | Around the base of tanks welding bead | H section steel | Angle section steel / Channel section steel |

1 Cleaning

Remove rust from the pipe surface using wire brush, hammer etc. When preparation of the surface is finished, wipe away dirt, moisture and oil thoroughly with waste cloth.



2 Undercoat

Evenly apply Nitohullmac XG-PN (primer) by gloves. Make sure that the primer is mixed well before use. The standard amount applied per coat is 0.2kg/m²-0.3kg/m².

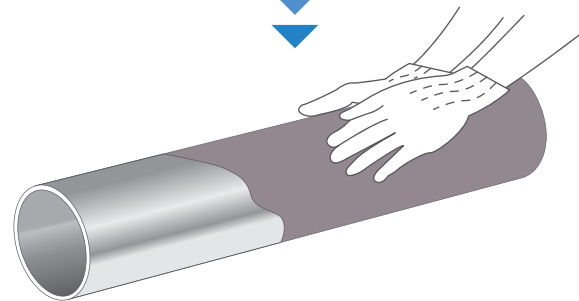

3 Application of tape

Gently pulling the Nitohullmac XG (tape), wind it around the pipe by 55% lapping.

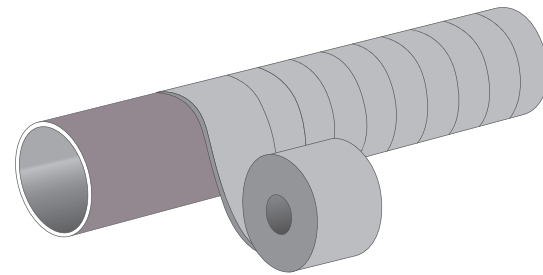

4 Smoothing

After winding the tape, smoothen thoroughly the tape applied with tools such as rubber gloves, pressing roller, rubber spatula etc. Carefully smoothen the tape especially on the edges and lap areas.

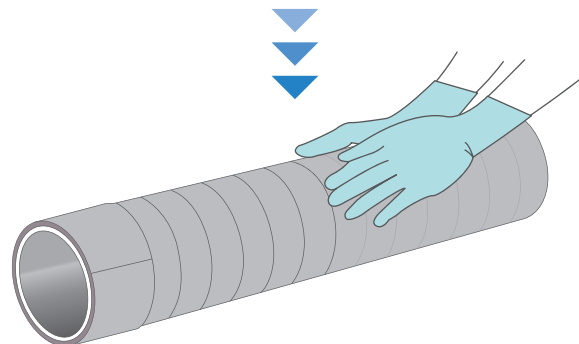

5 Topcoat

Evenly apply Nitohullmac XG-T or XG-TLW (topcoat) with a brush or a roller brush. The standard amount applied per coat is XG-T:0.3kg/m², XG-TLW:0.5kg/m².

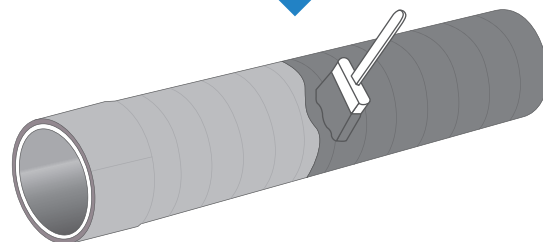

6 Inspection

Check visually and by hand touch to find any flaw, lift or disbondment. Especially, carefully check the lower side and back side which are less visible.

Elbows

Application procedure

| Straight pipes | Elbows | Tees | Flanges | Valves |
|--------------------------|---|---------------------------------------|-----------------|---|
| Around the base of tanks | Around the base of tanks reinforcing member | Around the base of tanks welding bead | H section steel | Angle section steel / Channel section steel |

1 Cleaning

Remove rust from the pipe surface using wire brush, hammer etc. When preparation of the surface is finished, wipe away dirt, moisture and oil thoroughly with waste cloth.

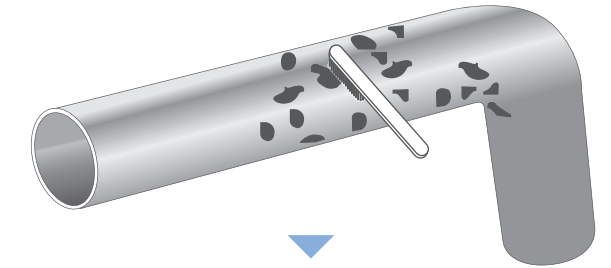

2 Undercoat

Evenly apply Nitohullmac XG-PN (primer) by gloves. Make sure that the primer is mixed well before use. The standard amount applied per coat is 0.2kg/m²-0.3kg/m².

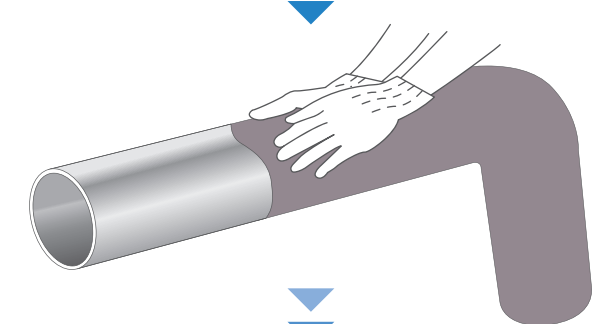

3 Application of tape

Gently pulling the Nitohullmac XG (tape), wind it around the pipe by 55% lapping.

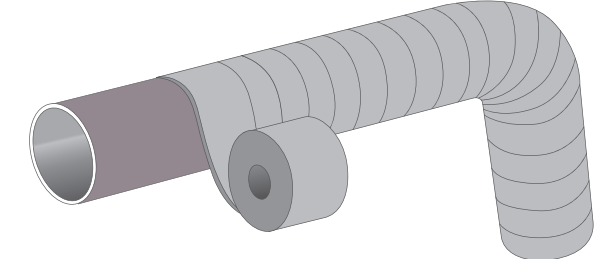

4 Smoothing

After winding the tape, smoothen thoroughly the tape applied with tools such as rubber gloves, pressing roller, rubber spatula etc. Carefully smoothen the tape especially on the edges and lap areas.

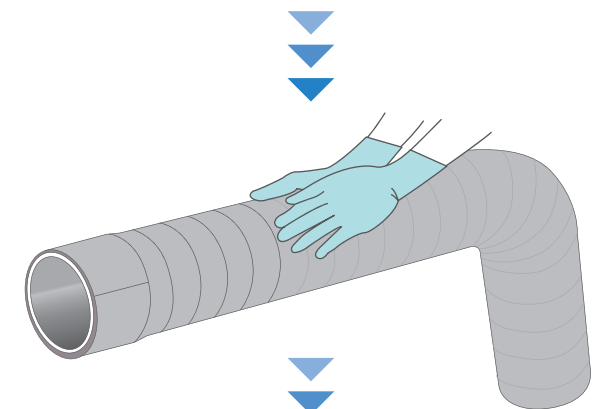

5 Topcoat

Evenly apply Nitohullmac XG-T or XG-TLW (topcoat) with a brush or a roller brush. The standard amount applied per coat is XG-T:0.3kg/m², XG-TLW:0.5kg/m².

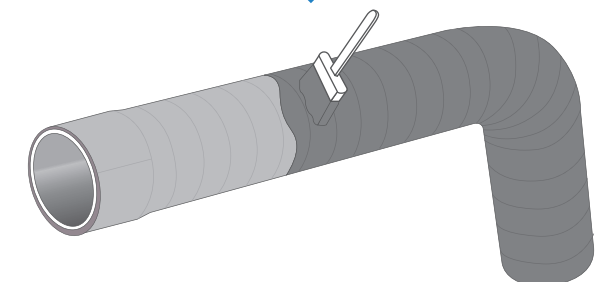

6 Inspection

Check visually and by hand touch to find any flaw, lift or disbondment. Especially, carefully check the lower side and back side which are less visible.

Tees

Application procedure

| Straight pipes | Elbows | Tees | Flanges | Valves |
|--------------------------|---|---------------------------------------|-----------------|---|
| Around the base of tanks | Around the base of tanks reinforcing member | Around the base of tanks welding bead | H section steel | Angle section steel / Channel section steel |

1 Cleaning

Remove rust from the pipe surface using wire brush, hammer etc. When preparation of the surface is finished, wipe away dirt, moisture and oil thoroughly with waste cloth.

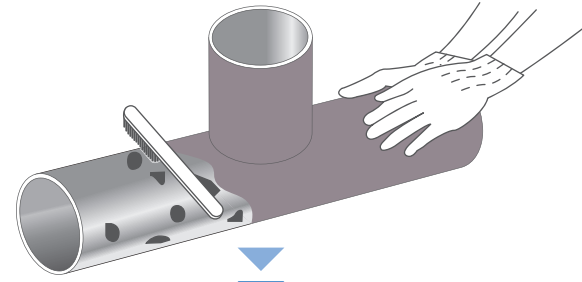

2 Undercoat

Evenly apply Nitohullmac XG-PN (primer) by gloves. Make sure that the primer is mixed well before use. The standard amount applied per coat is 0.2kg/m^2 - 0.3kg/m^2 .

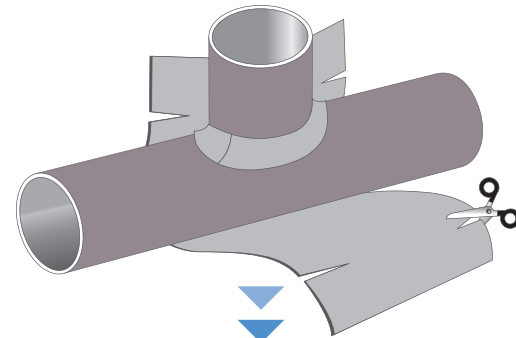

3 Application of tape

- (1) Apply the Nitohullmac XG (tape) to the corner.
- (2) Apply the wide tape to the irregularly shaped parts.
- (3) Wind the tape around the tee in the form of a cross.
- (4) Wind the tape around the riser starting from the bottom.

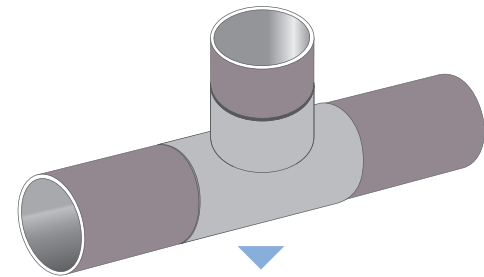

4 Smoothing

After winding the tape, smoothen thoroughly the tape applied with tools such as rubber gloves, pressing roller, rubber spatula etc. Carefully smoothen the tape especially on the edges and lap areas.

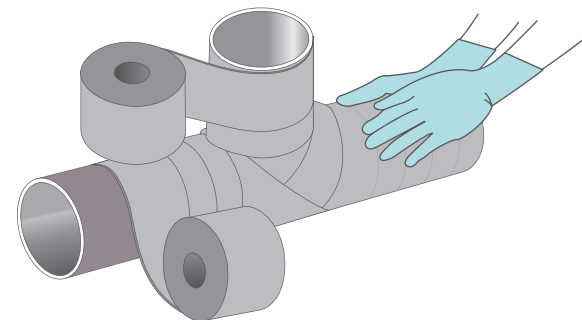

5 Topcoat

Evenly apply Nitohullmac XG-T or XG-TLW (topcoat) with a brush or a roller brush. The standard amount applied per coat is XG-T: 0.3kg/m^2 , XG-TLW: 0.5kg/m^2 .

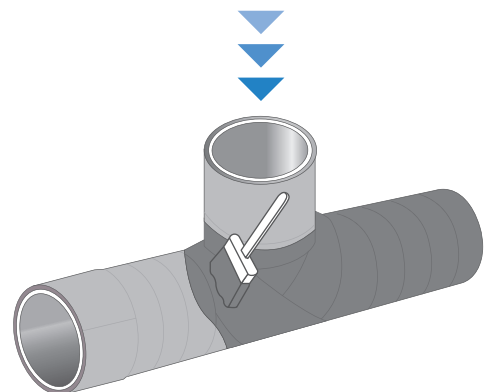

6 Inspection

Check visually and by hand touch to find any flaw, lift or disbondment. Especially, carefully check the lower side and back side which are less visible.

Flanges

Application procedure

| Straight pipes | Elbows | Tees | Flanges | Valves |
|--------------------------|---|---------------------------------------|-----------------|---|
| Around the base of tanks | Around the base of tanks reinforcing member | Around the base of tanks welding bead | H section steel | Angle section steel / Channel section steel |

1 Cleaning

Remove rust from the surface using wire brush, hammer etc. When preparation of the surface is finished, wipe away dirt, moisture and oil thoroughly with waste cloth.

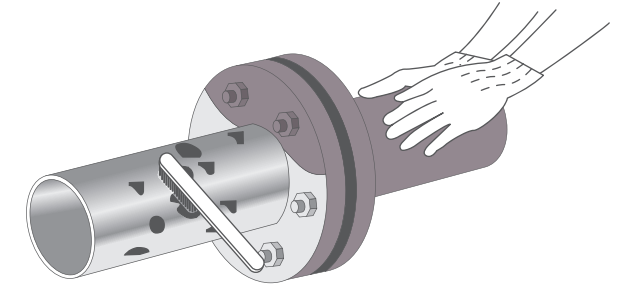

2 Undercoat

Evenly apply Nitohullmac XG-PN (primer) by gloves. Make sure that the primer is mixed well before use. The standard amount applied per coat is 0.2kg/m^2 - 0.3kg/m^2 .

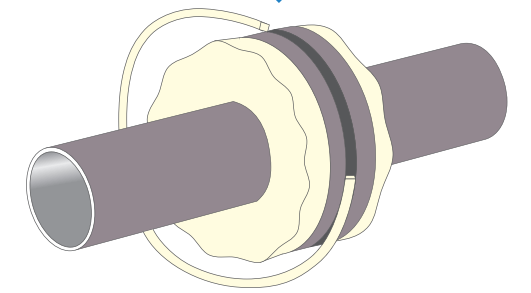

3 Application of tape

- (1) Fill the gap of flange with a strip of Nitohullmac XG (tape) or XG-M (filler).
- (2) Cover the bolts and nuts with XG-M (filler).
- (3) Wind the wide tape from the center of the flange, covering the left and right fillers, and gather up at each side. Make a cut in where the tape is gathered, to prevent undue lift of tape.
- (4) Wind the tape additionally around the center of flange.
- (5) Wind the tape around the straight pipe.

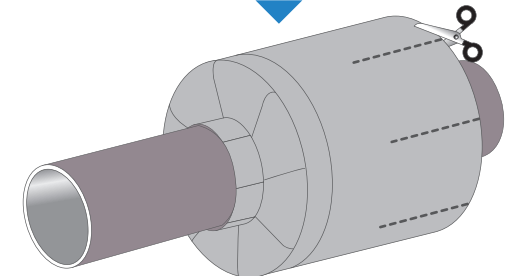

4 Smoothing

After winding the tape, smoothen thoroughly the tape applied with tools such as rubber gloves, pressing roller, rubber spatula etc. Carefully smoothen the tape especially on the edges and lap areas.

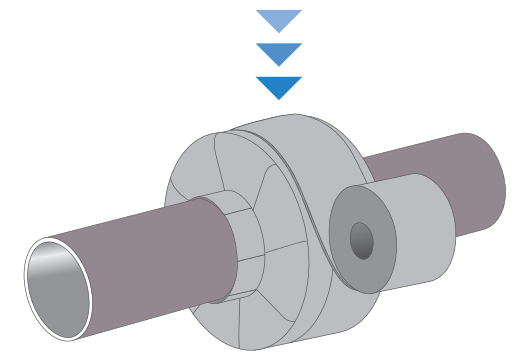

5 Topcoat

Evenly apply Nitohullmac XG-T or XG-TLW (topcoat) with a brush or a roller brush. The standard amount applied per coat is XG-T: 0.3kg/m^2 , XG-TLW: 0.5kg/m^2 .

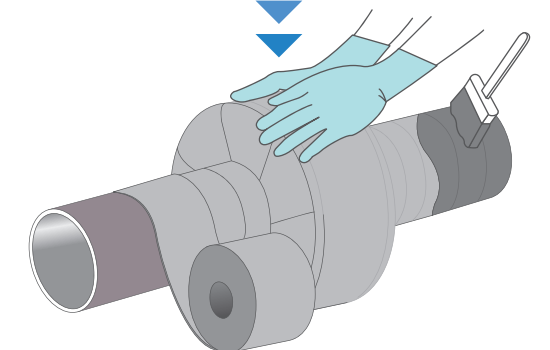

6 Inspection

Check visually and by hand touch to find any flaw, lift or disbondment. Especially, carefully check the lower side and back side which are less visible.

Valves

Application procedure

| Straight pipes | Elbows | Tees | Flanges | Valves |
|--------------------------|---|---------------------------------------|-----------------|---|
| Around the base of tanks | Around the base of tanks reinforcing member | Around the base of tanks welding bead | H section steel | Angle section steel / Channel section steel |

1 Cleaning

Remove rust from the surface using wire brush, hammer etc. When preparation of the surface is finished, wipe away dirt, moisture and oil thoroughly with waste cloth.

2 Undercoat

Evenly apply Nitohullmac XG-PN (primer) by gloves. Make sure that the primer is mixed well before use. The standard amount applied per coat is 0.2kg/m^2 - 0.3kg/m^2 .

3 Application of tape

- (1) For the valve flanges, apply the tape following the procedure specified for the flanges (P.4).
- (2) Wind the wide tape around the valve body.
- (3) When winding tape around the irregularly shaped part, make a cut in the tape to prevent undue lift of tape.
- (4) Wind the tape additionally around the left and right sides of the flange, its upper and lower sides, and the center.

4 Smoothing

After winding the tape, smoothen thoroughly the tape applied with tools such as rubber gloves, pressing roller, rubber spatula etc. Carefully smoothen the tape especially on the edges and lap areas.

5 Topcoat

Evenly apply Nitohullmac XG-T or XG-TLW (topcoat) with a brush or a roller brush. The standard amount applied per coat is XG-T: 0.3kg/m^2 , XG-TLW: 0.5kg/m^2 .

6 Inspection

Check visually and by hand touch to find any flaw, lift or disbondment. Especially, carefully check the lower side and back side which are less visible.

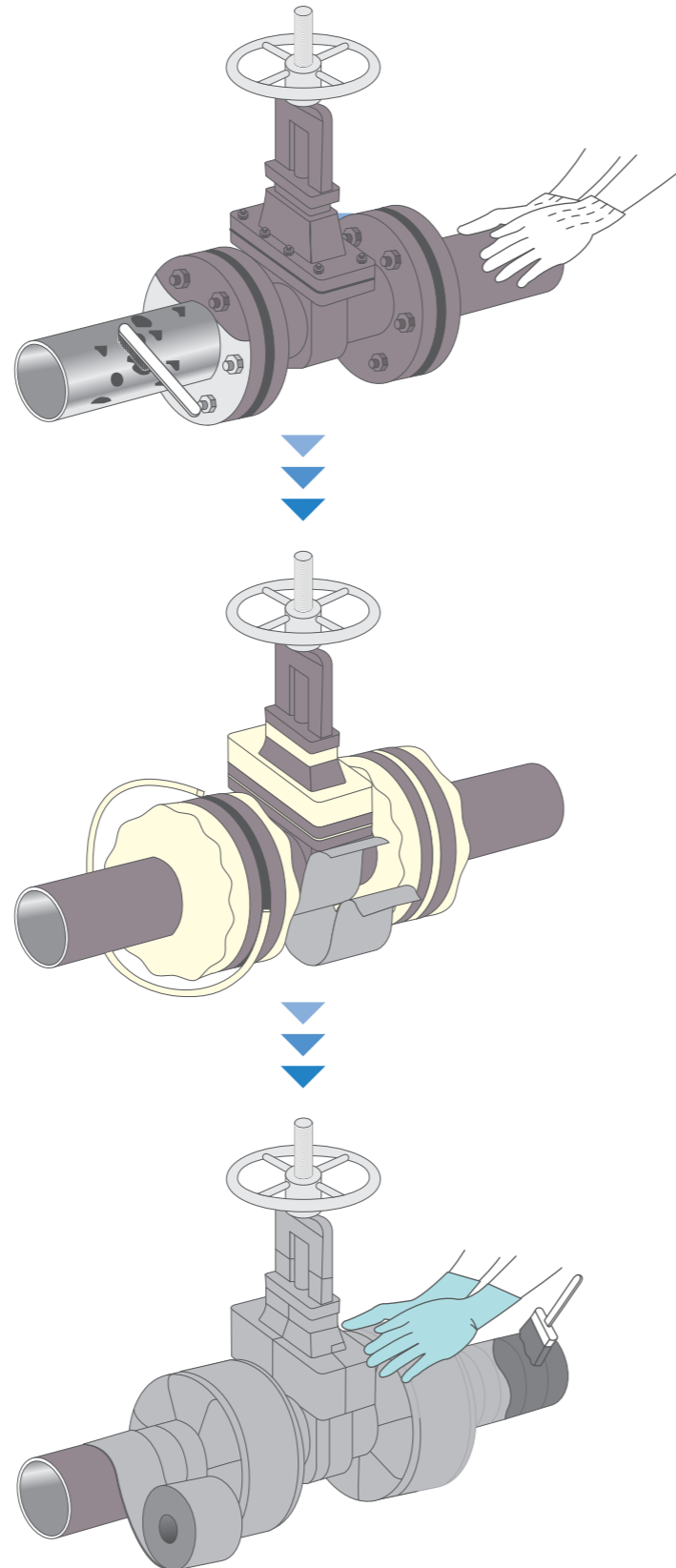

Around the base of tanks

Application procedure

| Straight pipes | Elbows | Tees | Flanges | Valves |
|--------------------------|---|---------------------------------------|-----------------|---|
| Around the base of tanks | Around the base of tanks reinforcing member | Around the base of tanks welding bead | H section steel | Angle section steel / Channel section steel |

1 Cleaning

Prepare the side surface and flange of the tank as with the straight pipe section. Remove the unevenness and flatten the mortar surface. When preparation is finished, remove dust, water and oil completely with waste cloth.

2 Undercoat

After mixing the primers well, evenly apply NITOHULLMAC XG-PN (primer) on the side / flange of the tank by gloves, and NITOPRIMER AF (primer) on the mortar surface using a brush or a roller brush. Apply two coats of AF on the mortar surface (apply the second coat when the first coat is dry to the touch). The standard amount applied per coat is XG-PN: 0.2kg/m^2 - 0.3kg/m^2 , AF: 0.2kg/m^2 .

3 Application of tape

- (1) Embed NITOHULLMAC XG-M (filler) in the corner area.
- (2) Cut a wide tape (200mm-300mm) into approx. 500mm-1000mm strips in advance, and apply them radially from the circumference of the tank.
- (3) Apply a wide tape (150mm) around the side of the tank.

4 Smoothing

After applying the tape, smoothen thoroughly with tools such as rubber gloves, pressing roller, rubber spatula etc. Carefully smoothen the tape especially on the edges and lap areas.

5 Topcoat

Evenly apply Nitohullmac XG-T or XG-TLW (topcoat) with a brush or a roller brush. The standard amount applied per coat is XG-T: 0.3kg/m^2 , XG-TLW: 0.5kg/m^2 .

6 Inspection

Check visually and by hand touch to find any flaw, lift or disbondment.

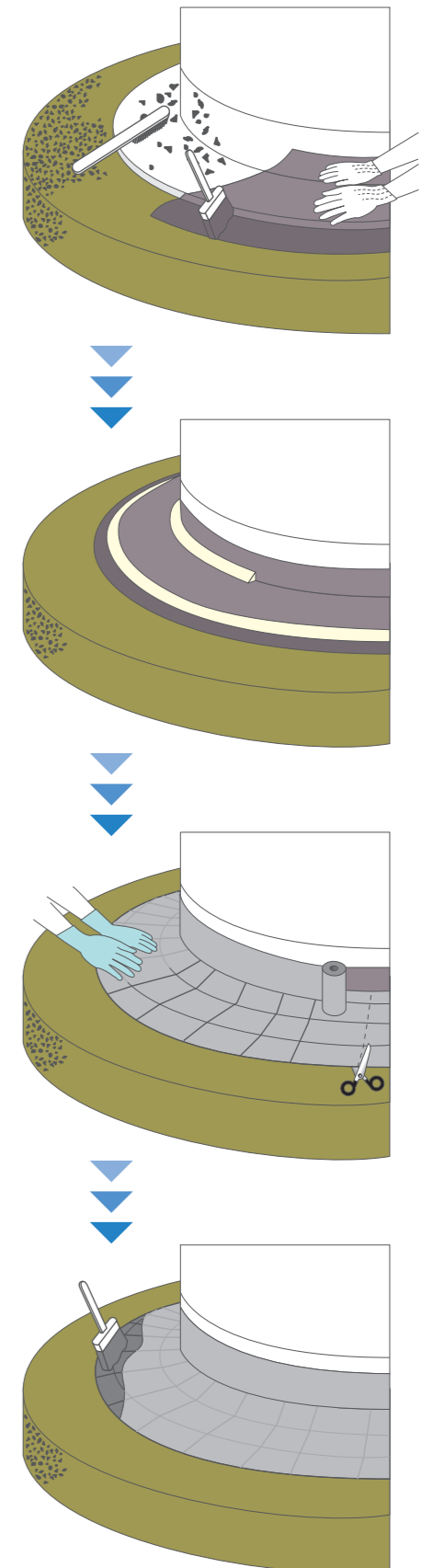

Around the base of tanks - reinforcing member

Application procedure

| Straight pipes | Elbows | Tees | Flanges | Valves |
|--------------------------|---|---------------------------------------|-----------------|---|
| Around the base of tanks | Around the base of tanks reinforcing member | Around the base of tanks welding bead | H section steel | Angle section steel / Channel section steel |

1 Cleaning

Prepare the side surface and flange of the tank as with the straight pipe section. Remove the unevenness and flatten the mortar surface. When preparation is finished, remove dust, water and oil completely with waste cloth.

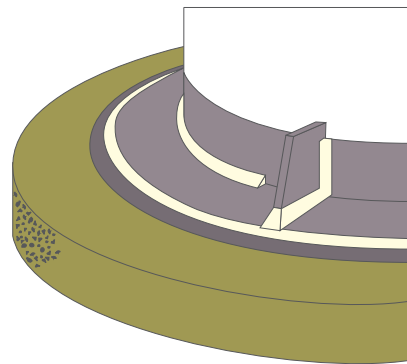

2 Undercoat

After mixing the primers well, evenly apply NITOHULLMAC XG-PN (primer) on the side / flange of the tank by gloves, and NITOPRIMER AF (primer) on the mortar surface using a brush or a roller brush. Apply two coats of AF on the mortar surface (apply the second coat when the first coat is dry to the touch). The standard amount applied per coat is XG-PN:0.2kg/m²-0.3kg/m², AF:0.2kg/m².

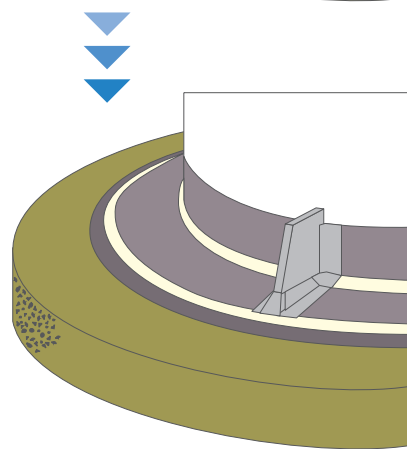

3 Application of tape

- (1) Embed NITOHULLMAC XG-M (filler) in the corner areas of the tank and reinforcing member.
- (2) Apply a wide tape (150mm) on the reinforcing member.
- (3) Cut a wide tape (200mm-300mm) into approx. 500mm-1000mm strips in advance, and apply them radially from the circumference of the tank. Cut off the section that overlaps the reinforcing member.
- (4) Apply a wide tape (150mm) around the side of the tank.

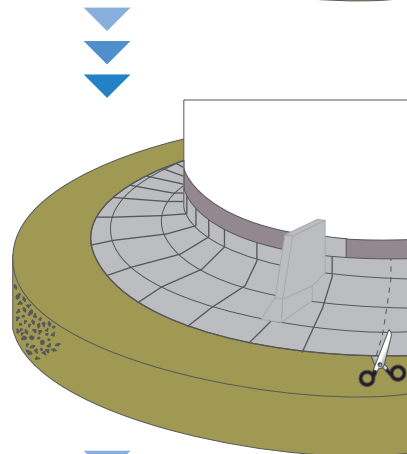

4 Smoothing

After applying the tape, smoothen thoroughly with tools such as rubber gloves, pressing roller, rubber spatula etc. Carefully smoothen the tape especially on the edges and lap areas.

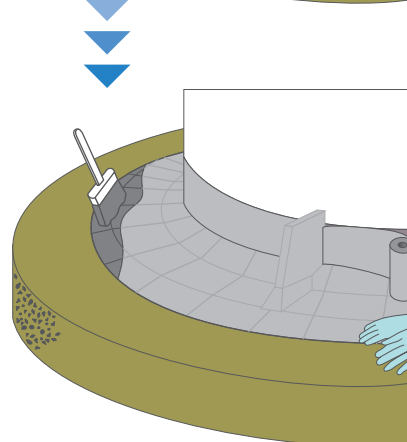

5 Topcoat

Evenly apply Nitohullmac XG-T or XG-TLW (topcoat) with a brush or a roller brush. The standard amount applied per coat is XG-T:0.3kg/m², XG-TLW:0.5kg/m².

6 Inspection

Check visually and by hand touch to find any flaw, lift or disbondment.

Around the base of tanks - welding bead

Application procedure

| Straight pipes | Elbows | Tees | Flanges | Valves |
|--------------------------|---|---------------------------------------|-----------------|---|
| Around the base of tanks | Around the base of tanks reinforcing member | Around the base of tanks welding bead | H section steel | Angle section steel / Channel section steel |

1 Cleaning

Prepare the side surface and flange of the tank as with the straight pipe section. Remove the unevenness and flatten the mortar surface. When preparation is finished, remove dust, water and oil completely with waste cloth.

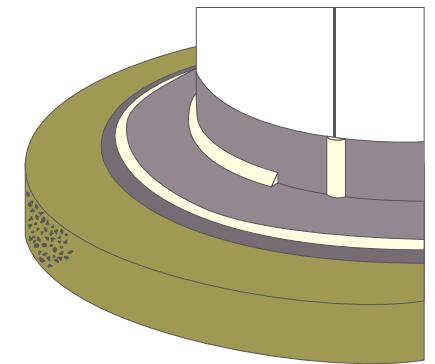

2 Undercoat

After mixing the primers well, evenly apply NITOHULLMAC XG-PN (primer) on the side / flange of the tank by gloves, and NITOPRIMER AF (primer) on the mortar surface using a brush or a roller brush. Apply two coats of AF on the mortar surface (apply the second coat when the first coat is dry to the touch). The standard amount applied per coat is XG-PN:0.2kg/m²-0.3kg/m², AF:0.2kg/m².

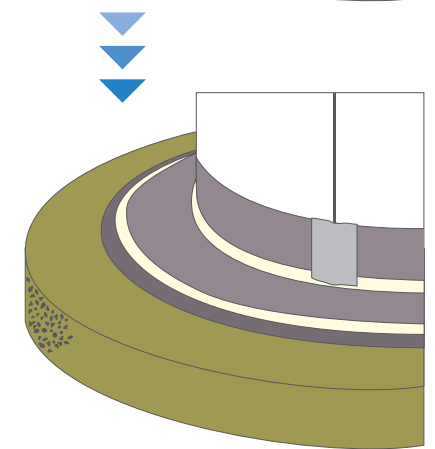

3 Application of tape

- (1) Embed NITOHULLMAC XG-M (filler) in the corner area of the tank and the welding bead.
- (2) Apply a narrow tape (100mm) on the welding bead.
- (3) Cut a wide tape (200mm-300mm) into approx. 500mm-1000mm strips in advance, and apply them radially from the circumference of the tank.
- (4) Apply a wide tape (150mm) around the side of the tank.

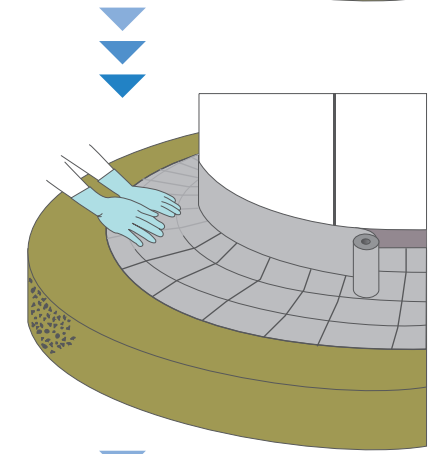

4 Smoothing

After applying the tape, smoothen thoroughly with tools such as rubber gloves, pressing roller, rubber spatula etc. Carefully smoothen the tape especially on the edges and lap areas.

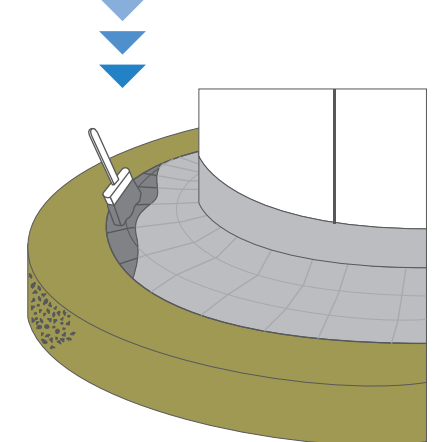

5 Topcoat

Evenly apply Nitohullmac XG-T or XG-TLW (topcoat) with a brush or a roller brush. The standard amount applied per coat is XG-T:0.3kg/m², XG-TLW:0.5kg/m².

6 Inspection

Check visually and by hand touch to find any flaw, lift or disbondment.

H section steel

Application procedure

| Straight pipes | Elbows | Tees | Flanges | Valves |
|--------------------------|---|---------------------------------------|-----------------|---|
| Around the base of tanks | Around the base of tanks reinforcing member | Around the base of tanks welding bead | H section steel | Angle section steel / Channel section steel |

1 Cleaning

Remove rust from the surface using wire brush, hammer etc. When preparation of the surface is finished, wipe away dirt, moisture and oil thoroughly with waste cloth.

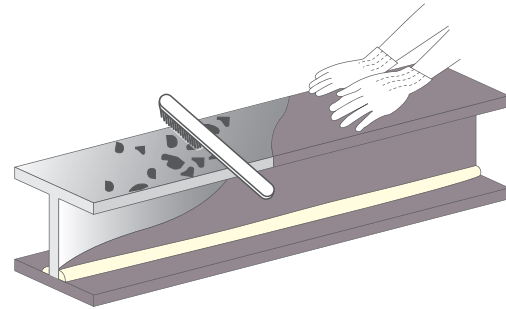

2 Undercoat

Evenly apply Nitohullmac XG-PN (primer) by gloves. Make sure that the primer is mixed well before use. The standard amount applied per coat is 0.2kg/m²-0.3kg/m².

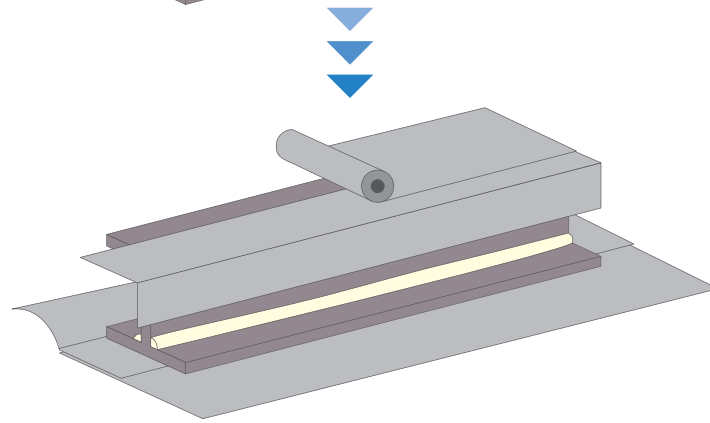

3 Application of tape

- (1) Embed NITOHULLMAC XG-M (filler) in the corner area.
- (2) Apply a wide tape on the top and bottom surfaces. Make sure that the folded area covers the corner area.
- (3) Apply a wide tape on the side.

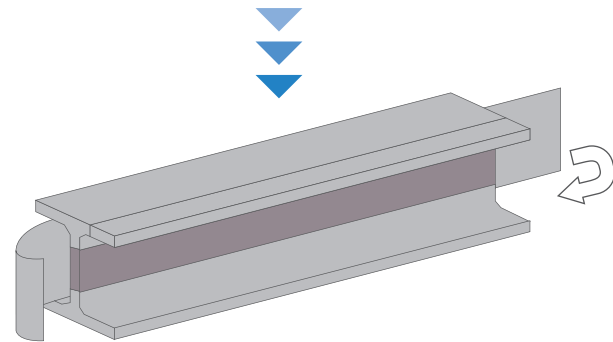

4 Smoothing

After applying the tape, smoothen thoroughly with tools such as rubber gloves, pressing roller, rubber spatula etc. Carefully smoothen the tape especially on the edges and lap areas.

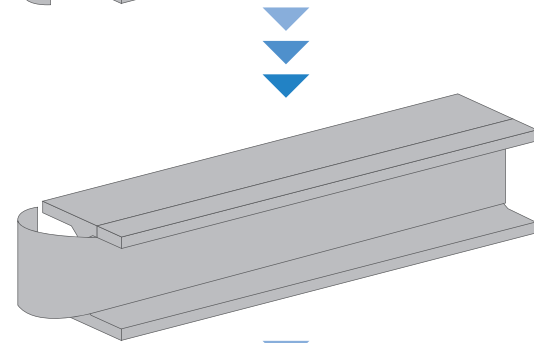

5 Topcoat

Evenly apply Nitohullmac XG-T or XG-TLW (topcoat) with a brush or a roller brush. The standard amount applied per coat is XG-T:0.3kg/m², XG-TLW:0.5kg/m².

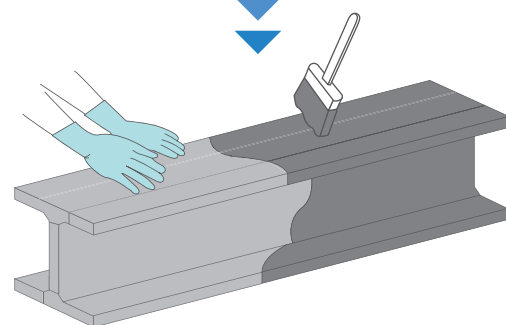

6 Inspection

Check visually and by hand touch to find any flaw, lift or disbondment. Especially, carefully check the lower side and back side which are less visible.

Angle section steel / Channel section steel

Application procedure

| Straight pipes | Elbows | Tees | Flanges | Valves |
|--------------------------|---|---------------------------------------|-----------------|---|
| Around the base of tanks | Around the base of tanks reinforcing member | Around the base of tanks welding bead | H section steel | Angle section steel / Channel section steel |

1 Cleaning

Remove rust from the surface using wire brush, hammer etc. When preparation of the surface is finished, wipe away dirt, moisture and oil thoroughly with waste cloth.

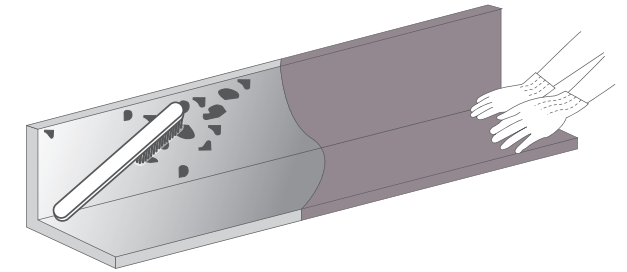

2 Undercoat

Evenly apply Nitohullmac XG-PN (primer) by gloves. Make sure that the primer is mixed well before use. The standard amount applied per coat is 0.2kg/m²-0.3kg/m².

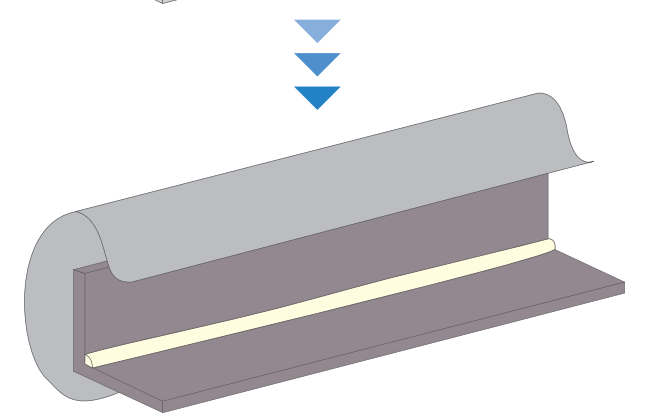

3 Application of tape

- (1) Embed NITOHULLMAC XG-M (filler) in the corner area.
- (2) Apply a wide tape from both sides, making sure that it covers the corner area.

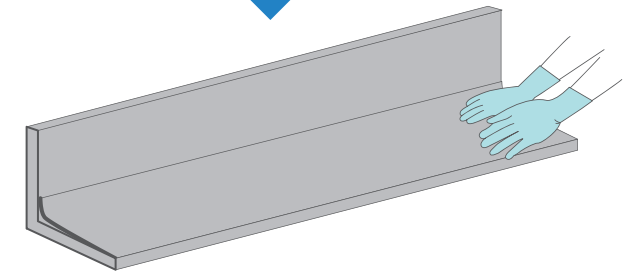

4 Smoothing

After applying the tape, smoothen thoroughly with tools such as rubber gloves, pressing roller, rubber spatula etc. Carefully smoothen the tape especially on the edges and lap areas.

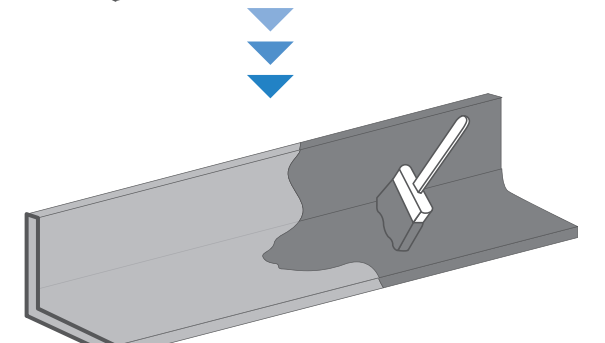

5 Topcoat

Evenly apply Nitohullmac XG-T or XG-TLW (topcoat) with a brush or a roller brush. The standard amount applied per coat is XG-T:0.3kg/m², XG-TLW:0.5kg/m².



6 Inspection

Check visually and by hand touch to find any flaw, lift or disbondment. Especially, carefully check the lower side and back side which are less visible.

